

## FEATURES

Complementary to S9015

MARKING: J6

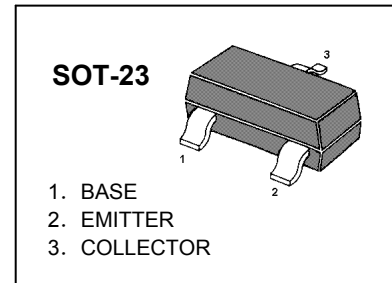

## MAXIMUM RATINGS (T<sub>A</sub>=25°C unless otherwise noted)

Symbol	Parameter	value	units
V <sub>CBO</sub>	Collector-Base Voltage	50	V
V <sub>CEO</sub>	Collector-Emitter Voltage	45	V
V <sub>EBO</sub>	Emitter-Base Voltage	5	V
I <sub>C</sub>	Collector Current-Continuous	0.1	A
P <sub>C</sub>	Collector Power Dissipation	0.2	W
T <sub>J</sub>	Junction Temperature	150	°C
T <sub>STG</sub>	Storage Temperature	-55-150	°C

## ELECTRICAL CHARACTERISTICS (T<sub>amb</sub>=25°C unless otherwise specified)

Parameter	Symbol	Test conditions	MIN	TYP	MAX	UNIT
Collector-base breakdown voltage	V <sub>(BR)CBO</sub>	I <sub>C</sub> = 100μA, I <sub>E</sub> =0	50			V
Collector-emitter breakdown voltage	V <sub>(BR)CEO</sub>	I <sub>C</sub> = 0.1mA, I <sub>B</sub> =0	45			V
Emitter-base breakdown voltage	V <sub>(BR)EBO</sub>	I <sub>E</sub> =100μA, I <sub>C</sub> =0	5			V
Collector cut-off current	I <sub>CBO</sub>	V <sub>CB</sub> =50V, I <sub>E</sub> =0			0.1	μA
Collector cut-off current	I <sub>CEO</sub>	V <sub>CE</sub> =35V, I <sub>B</sub> =0			0.1	μA
Emitter cut-off current	I <sub>EBO</sub>	V <sub>EB</sub> = 3V, I <sub>C</sub> =0			0.1	μA
DC current gain	h <sub>FE</sub>	V <sub>CE</sub> =5V, I <sub>C</sub> = 1mA	200		450	
Collector-emitter saturation voltage	V <sub>CE(Sat)</sub>	I <sub>C</sub> =100 mA, I <sub>B</sub> = 5mA			0.3	V
Base-emitter saturation voltage	V <sub>BE(Sat)</sub>	I <sub>C</sub> =100 mA, I <sub>B</sub> = 5mA			1	V
Transition frequency	f <sub>T</sub>	V <sub>CE</sub> =5V, I <sub>C</sub> = 10mA f=30MHZ	150			MHZ

**Typical Characteristics**

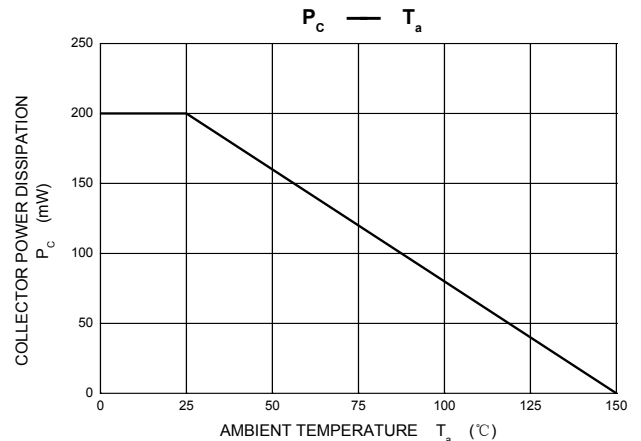
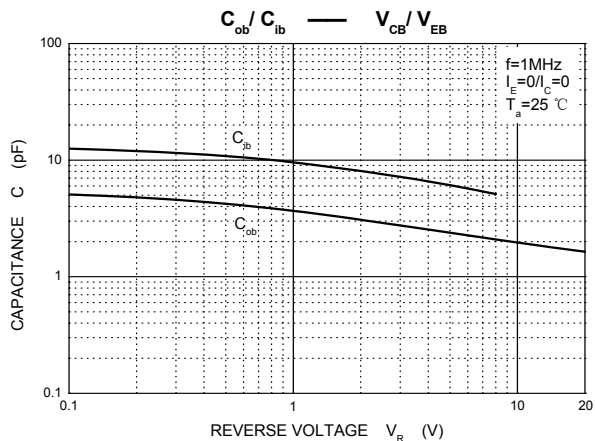
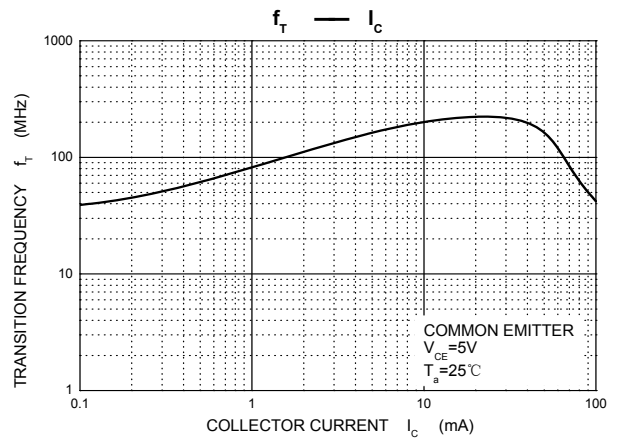
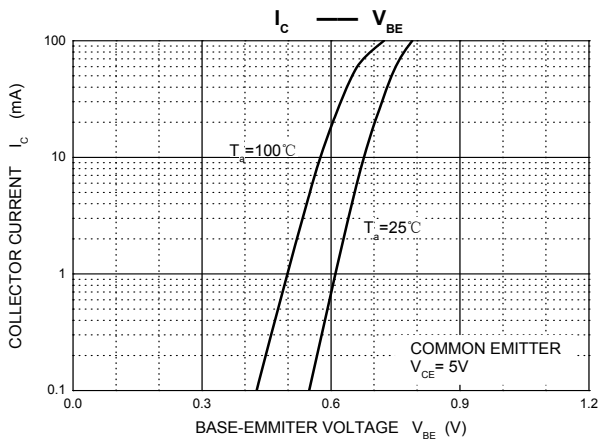
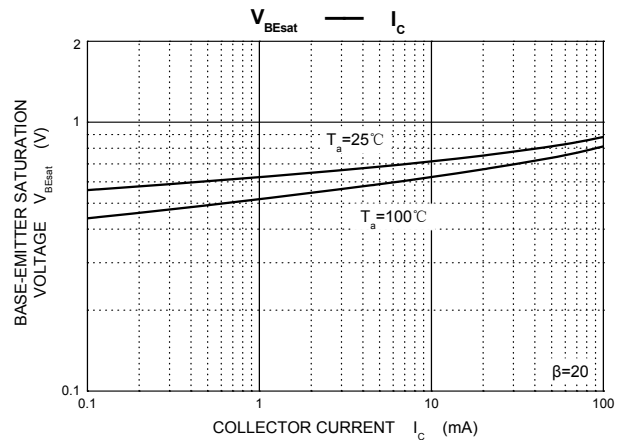
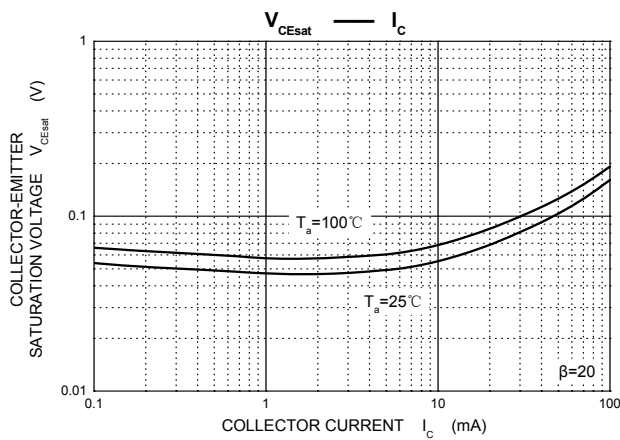
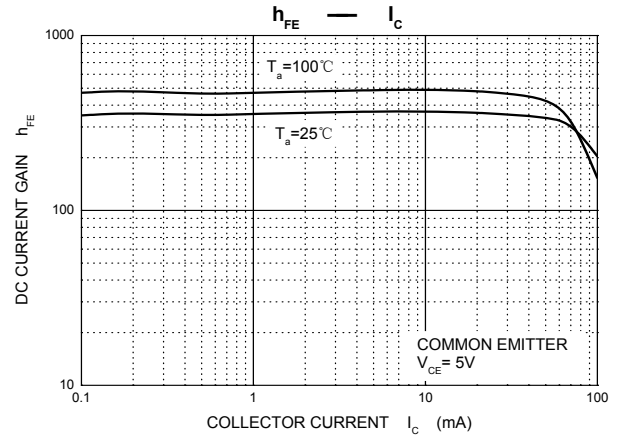
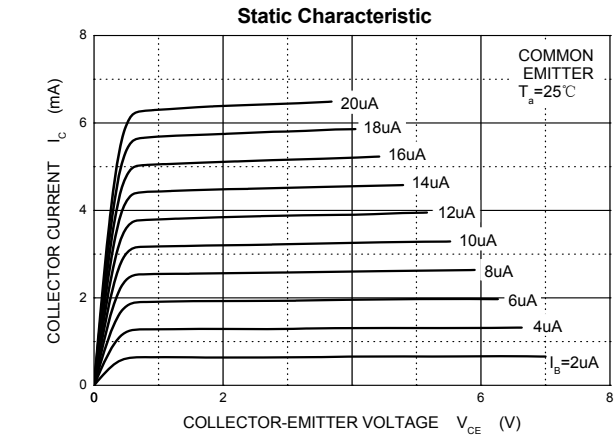

**PACKAGE OUTLINE**

Plastic surface mounted package; 3 leads

SOT-23

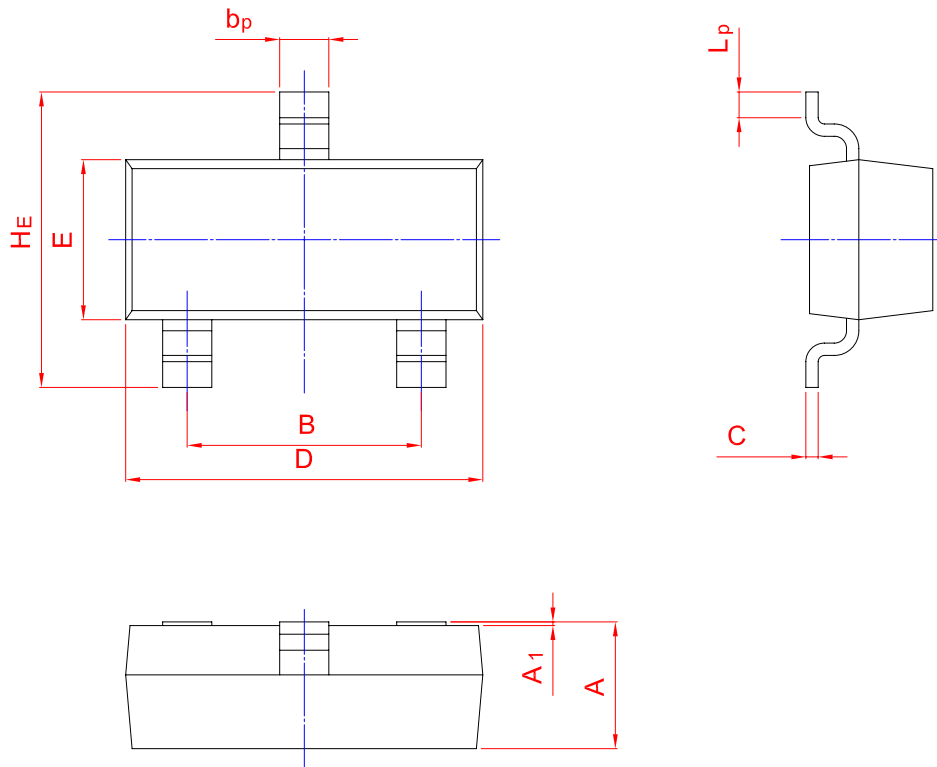
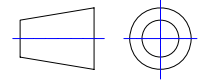

UNIT	A	B	bp	C	D	E	HE	A1	Lp
mm	1.40	2.04	0.50	0.19	3.10	1.65	3.00	0.100	0.50
	0.95	1.78	0.35	0.08	2.70	1.20	2.20	0.013	0.20