

# 4D $\Phi 4.6 \times 15$ RoHS Compliant

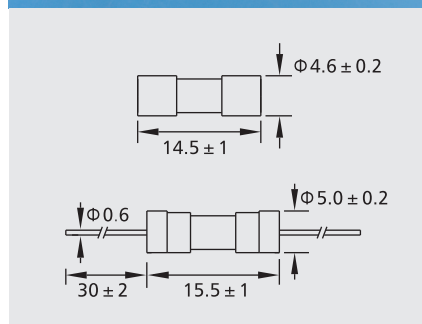

## 玻璃保险丝管(快断型) Glass Tube Fuse (Fast-Acting) 250V/125V

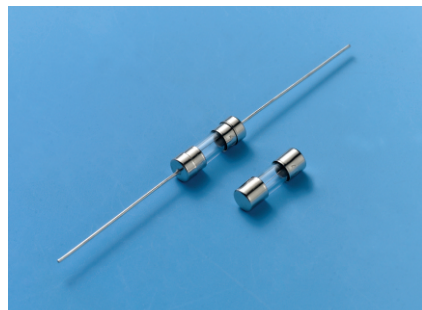

测试标准:  
Testing Standard:  
UL248-1 UL248-14

额定分断能力:  
Interrupting Rating:  
10000 Amperes at 125V AC  
35 Amperes at 250V AC(100mA~1A)  
25 Amperes at 250V AC(1.25A~1.6A)  
50 Amperes at 250V AC(2A~3.5A)

工作温度:  
Operating Temperature:  
-55°C ~ +125°C

材料:  
Materials:  
End cap:nickel plated brass  
Glass tube:glass  
Lead wire:tinned copper wire  
Inner cap:nickel plated brass

焊接方法:  
Soldering Method:  
Wave soldering: 260°C, 10s max  
Manual soldering: 350°C, 5s max

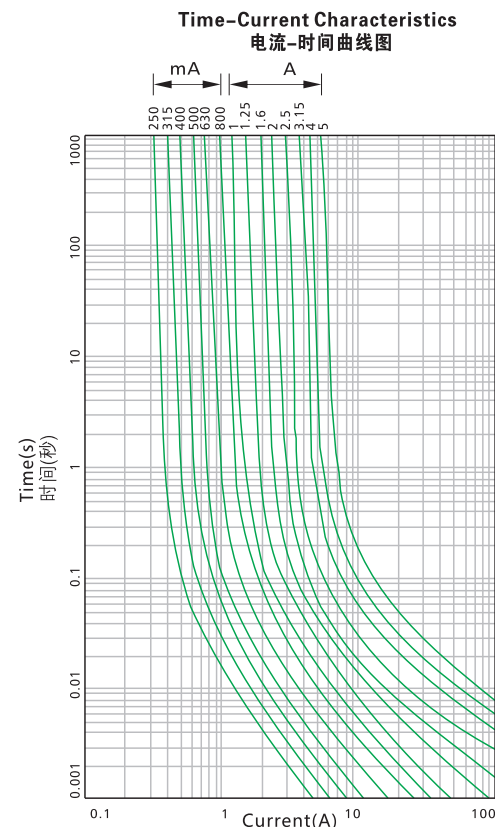

### 电气特性: Electrical Characteristics

额定电流的% % of Ampere Rating	熔断时间 Opening Time
100%	4 hours Min (大于4小时)
135%	1 hour Max(小于1小时)
200%	5 s Max(小于5秒)

目录编号: Catalog No.A:250V B:125V 带引线产品目录编号后加"P":Suffix"P"for Lead Type After Catalog No.

目录编号 Catalog No.	额定电流 Ampere Rating	额定电压 Voltage Rating	熔化热能 <sup>2</sup> T Melting Integral (A <sup>2</sup> .S)	认证 Approvals		
4D0100A/B	100mA	250/125V	0.002	●	●	
4D0125A/B	125mA	250/125V	0.003	●	●	
4D0160A/B	160mA	250/125V	0.008	●	●	
4D0200A/B	200mA	250/125V	0.015	●	●	
4D0250A/B	250mA	250/125V	0.020	●	●	
4D0300A/B	300mA	250/125V	0.035	●	●	
4D0315A/B	315mA	250/125V	0.05	●	●	
4D0350A/B	350mA	250/125V	0.06	●	●	
4D0400A/B	400mA	250/125V	0.07	●	●	
4D0500A/B	500mA	250/125V	0.10	●	●	
4D0630A/B	630mA	250/125V	0.22	●	●	
4D0750A/B	750mA	250/125V	0.30	●	●	
4D0800A/B	800mA	250/125V	0.37	●	●	
4D1100A/B	1A	250/125V	0.80	●	●	
4D1125A/B	1.25A	250/125V	1.3	●		●
4D1150A/B	1.5A	250/125V	1.9	●		●
4D1160A/B	1.6A	250/125V	2.2	●		●
4D1200A/B	2A	250/125V	3.2	●		●
4D1250A/B	2.5A	250/125V	5.1	●		●
4D1300A/B	3A	250/125V	6.7	●		●
4D1315A/B	3.15A	250/125V	7.8	●		●
4D1350A/B	3.5A	250/125V	10	●		●
4D1400B	4A	125V	15	●		
4D1500B	5A	125V	26	●		

● 表示已获认证  
● 表示认证中