

IGBT Modules

V_{CES}	1200V
I_c	75A

Applications

- Inverter for motor drive
- AC and DC servo drive amplifier
- UPS (Uninterruptible Power Supplies)
- Soft switching welding machine

Features

- Low $V_{ce(sat)}$ with Trench technology
- $V_{ce(sat)}$ with positive temperature coefficient
- High short circuit capability(10us)
- Including ultra fast & soft recovery anti-parallel FWD
- Low inductance
- Maximum junction temperature 175°C

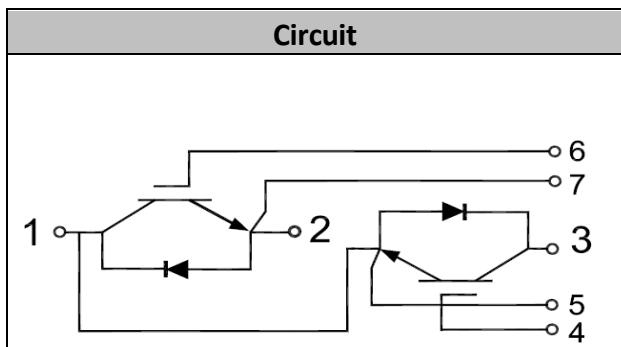

● IGBT

Absolute Maximum Ratings

Parameter	Symbol	Conditions	Value	Unit
Collector-Emitter Voltage	V_{CES}	$V_{GE}=0V, I_c=1mA, T_{vj}=25^{\circ}C$	1200	V
Continuous Collector Current	I_c	$T_c=100^{\circ}C$	75	A
Repetitive Peak Collector Current	I_{CRM}	$t_p=1ms$	150	A
Gate-Emitter Voltage	V_{GES}	$T_{vj}=25^{\circ}C$	± 20	V
Total Power Dissipation	P_{tot}	$T_c=25^{\circ}C$ $T_{vjmax}=175^{\circ}C$	530	W



Characteristic values

Parameter	Symbol	Conditions	Value			Unit	
			Min.	Typ.	Max.		
Gate-emitter Threshold Voltage	$V_{GE(th)}$	$V_{GE}=V_{CE}, I_C=3mA, T_{vj}=25^{\circ}C$	5.0	6.2	7.0	V	
Collector-Emitter Cut-off Current	I_{CES}	$V_{CE}=1200V, V_{GE}=0V, T_{vj}=25^{\circ}C$			1.0	mA	
Collector-Emitter Saturation Voltage	$V_{CE(sat)}$	$I_C=75A, V_{GE}=15V, T_{vj}=25^{\circ}C$		1.85		V	
		$I_C=75A, V_{GE}=15V, T_{vj}=125^{\circ}C$		2.05			
Input Capacitance	C_{ies}	$V_{CE}=25V, V_{GE}=0V,$ $f=1MHz, T_{vj}=25^{\circ}C$		5.52		nF	
Reverse Transfer Capacitance	C_{res}			0.26		nF	
Gate-Emitter leakage current	I_{GES}	$V_{CE}=0V, V_{GE}=20V, T_{vj}=25^{\circ}C$			400	nA	
Turn-on Delay Time	$t_{d(on)}$	$I_C=75A$ $V_{CE}=600V$ $V_{GE}=\pm 15V$ $R_G=10\Omega$ $T_{vj}=25^{\circ}C$		305		ns	
Rise Time	t_r			67		ns	
Turn-off Delay Time	$t_{d(off)}$			328		ns	
Fall Time	t_f			187		ns	
Energy Dissipation During Turn-on Time	E_{on}			6.7		mJ	
Energy Dissipation During Turn-off Time	E_{off}			4.3		mJ	
Turn-on Delay Time	$t_{d(on)}$		$I_C=75A$ $V_{CE}=600V$ $V_{GE}=\pm 15V$ $R_G=10\Omega$ $T_{vj}=125^{\circ}C$		311		ns
Rise Time	t_r				70		ns
Turn-off Delay Time	$t_{d(off)}$				347		ns
Fall Time	t_f				337		ns
Energy Dissipation During Turn-on Time	E_{on}			9.7		mJ	
Energy Dissipation During Turn-off Time	E_{off}			7.0		mJ	
SC Data	I_{sc}	$T_p \leq 10\mu s, V_{GE}=15V,$ $T_{vj}=150^{\circ}C, V_{cc}=600V,$ $V_{CEM} \leq 1200V$			420		A



● Diode

Absolute Maximum Ratings

Parameter	Symbol	Conditions	Value	Unit
Repetitive Peak Reverse Voltage	V_{RRM}	$T_{vj}=25^{\circ}C$	1200	V
Continuous DC Forward Current	I_F		75	A
Repetitive Peak Forward Current	I_{FRM}	$t_p=1ms$	150	A

Characteristic values

Parameter	Symbol	Conditions	Value			Unit
			Min.	Typ.	Max.	
Forward Voltage	V_F	$I_F=75A, T_{vj}=25^{\circ}C$		2.10		V
		$I_F=75A, T_{vj}=125^{\circ}C$		2.00		
Recovered Charge	Q_{rr}	$I_F = 75A$		4.8		μC
Peak Reverse Recovery Current	I_{rr}	$V_R=600V$ $-di_F/dt = 1200A/\mu s$		60		A
Reverse Recovery Energy	E_{rec}	$T_{vj}=25^{\circ}C$		3.8		mJ
Recovered Charge	Q_{rr}	$I_F = 75 A$		10.2		μC
Peak Reverse Recovery Current	I_{rr}	$V_R=600V$ $-di_F/dt = 1200A/\mu s$		77		A
Reverse Recovery Energy	E_{rec}	$T_{vj}=125^{\circ}C$		5.7		mJ



● Module Characteristics

T_c=25°C unless otherwise specified

Parameter	Symbol	Conditions	Value			Unit
			Min.	Typ.	Max.	
Isolation voltage	V _{isol}	t=1min,f=50Hz	2500			V
Maximum Junction Temperature	T _{jmax}				175	°C
Operating Junction Temperature	T _{vj op}		-40		150	°C
Storage Temperature	T _{stg}		-40		125	°C
Thermal Resistance Junction-to Case	R _{θJC}	per IGBT			0.26	K/W
		per Diode			0.42	
Thermal Resistance Case-to Sink	R _{θCS}	Conductive grease applied		0.05		K/W
Module Electrodes Torque	M _t	Recommended(M5)	2.5		5.0	N·m
Module-to-Sink Torque	M _s	Recommended(M6)	3.0		5.0	N·m
Weight of Module	G			150		g

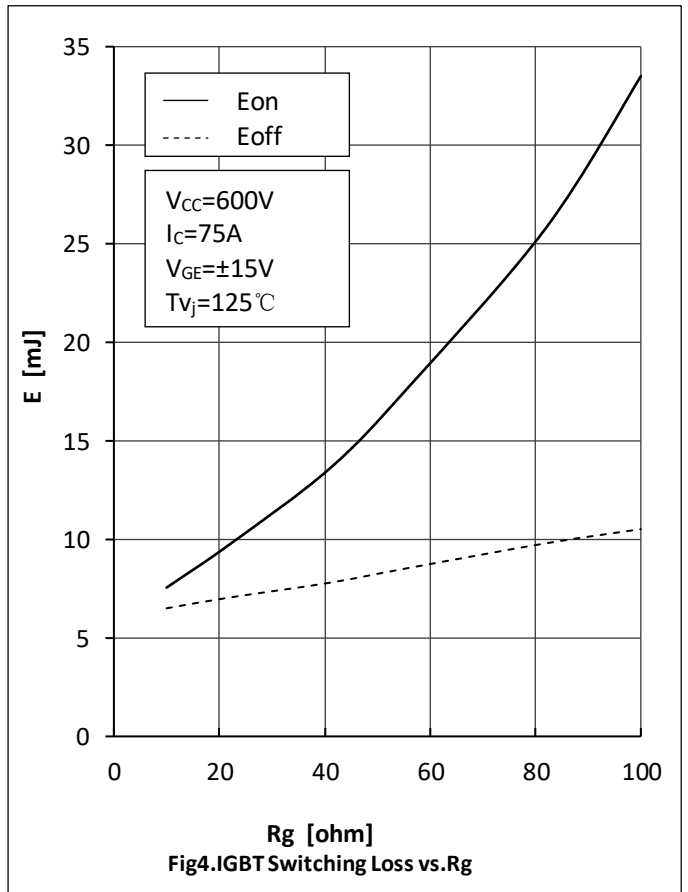
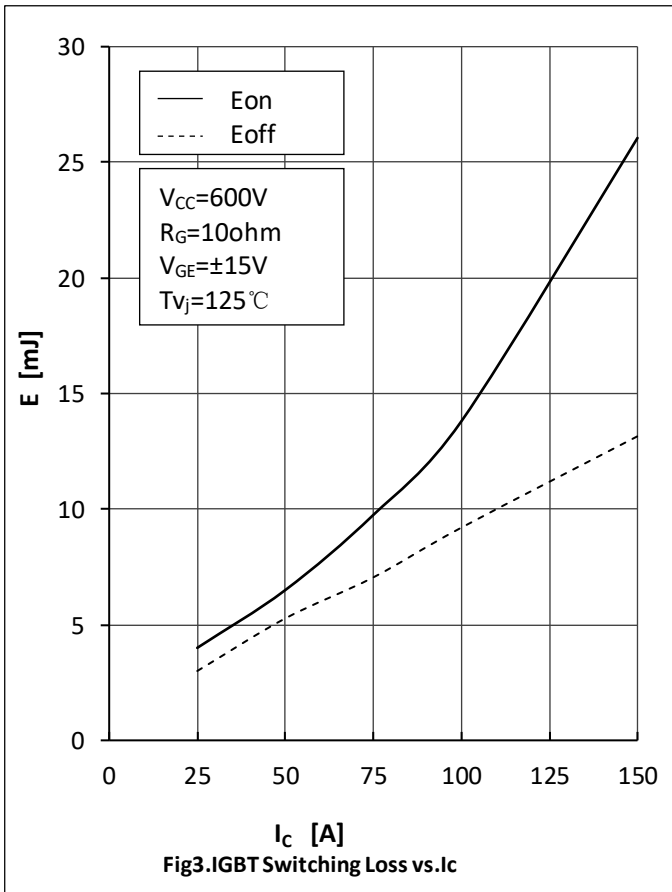
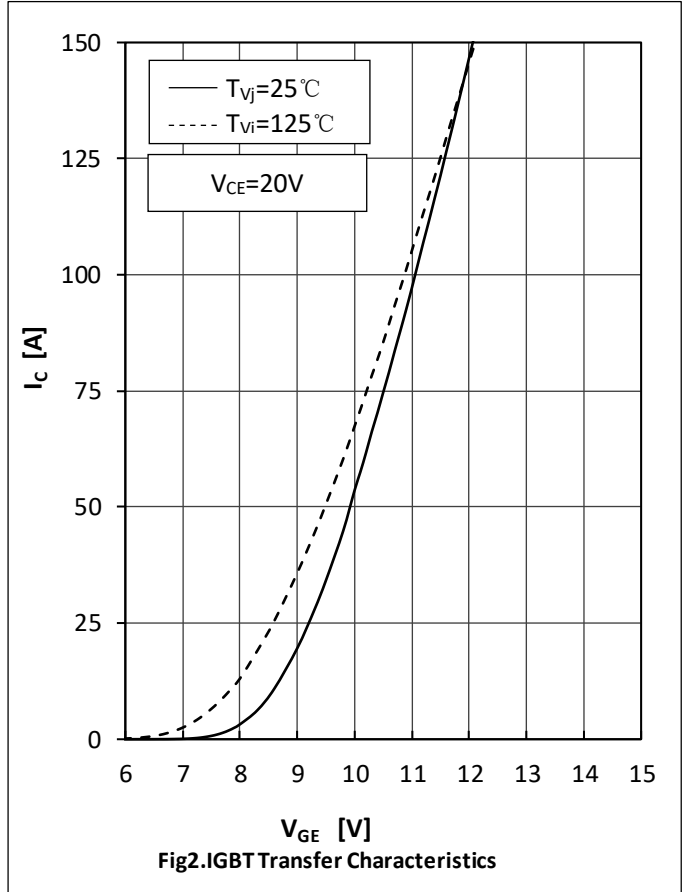
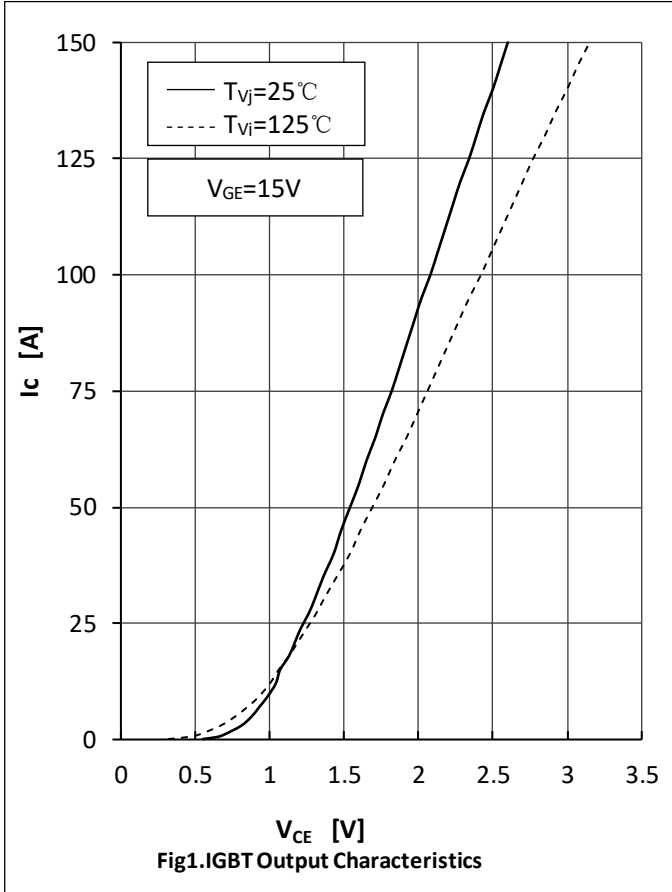

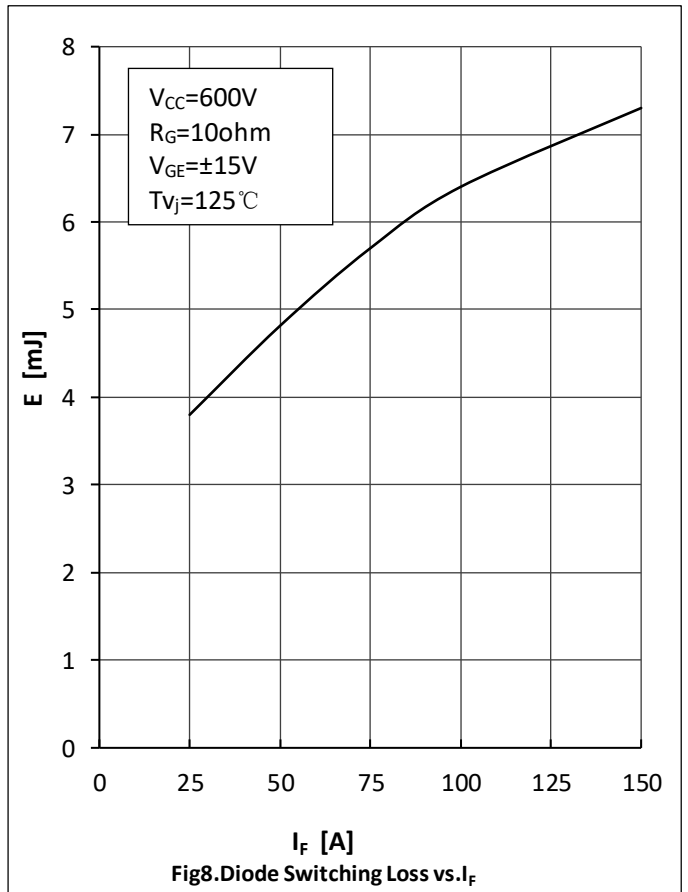
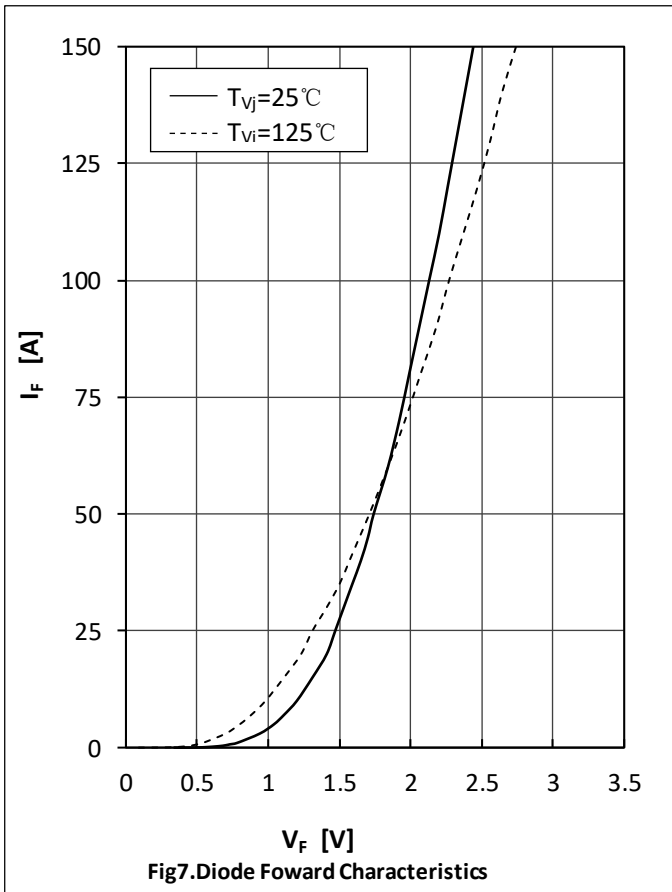
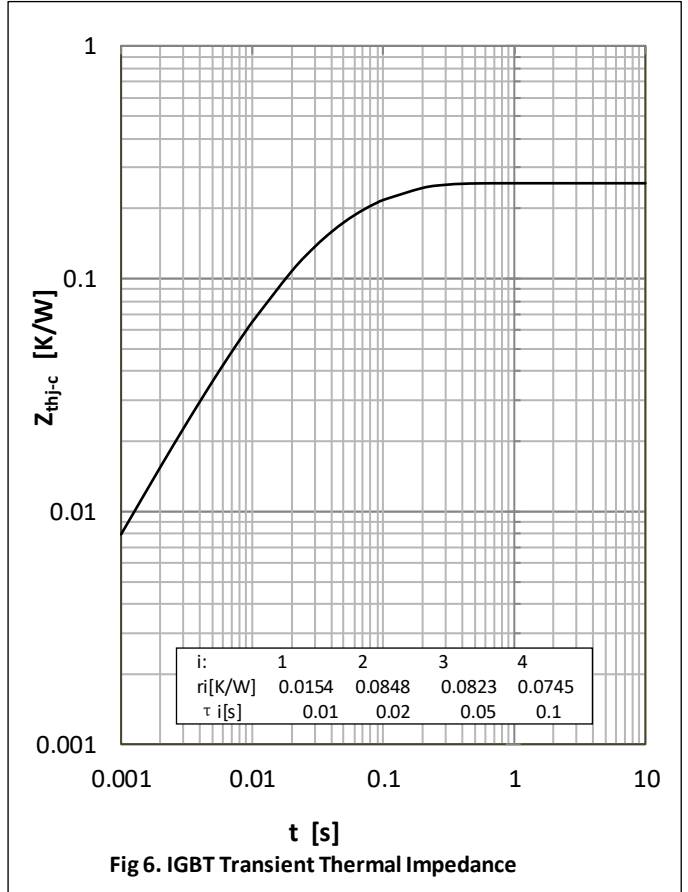
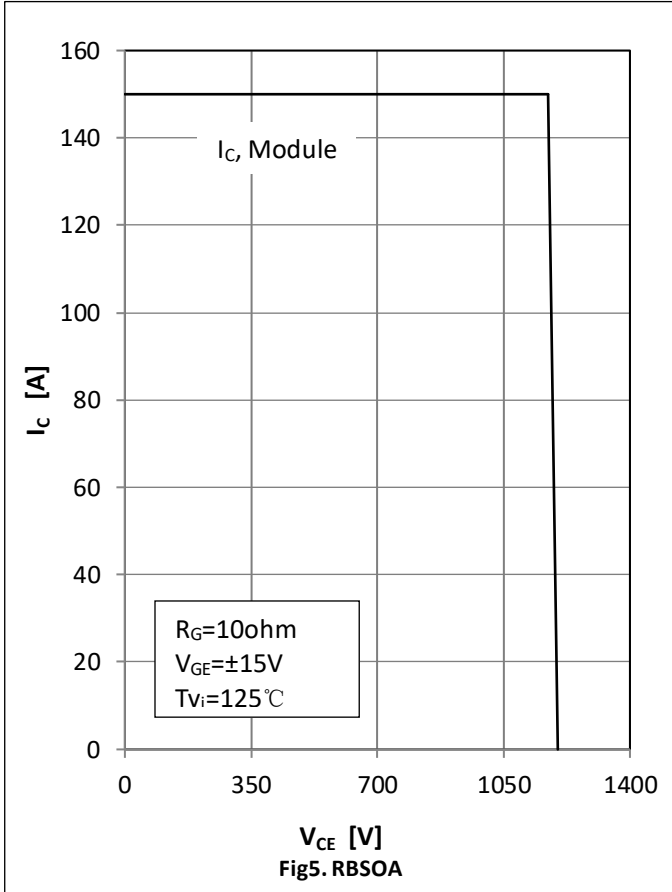

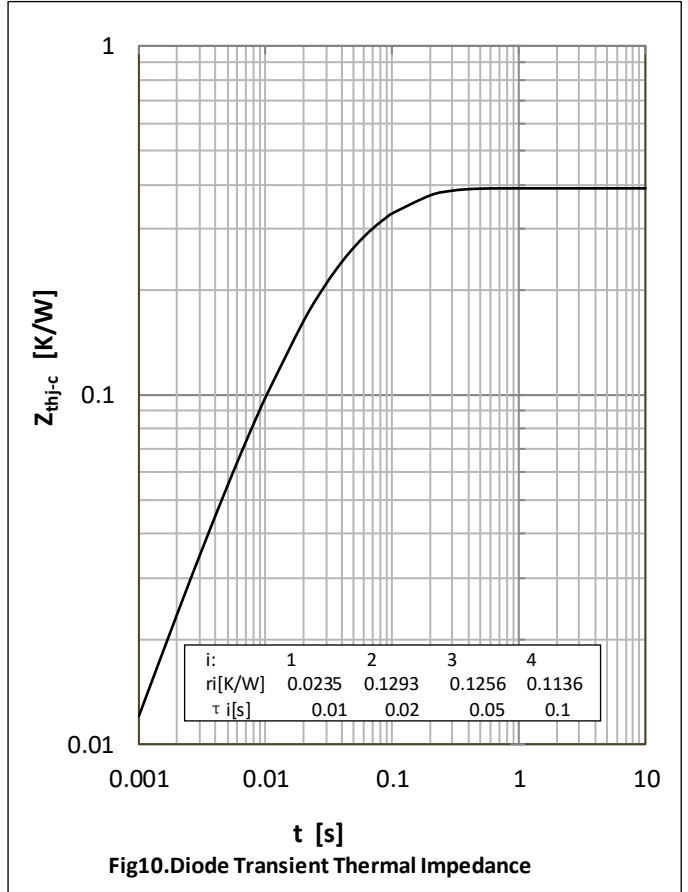
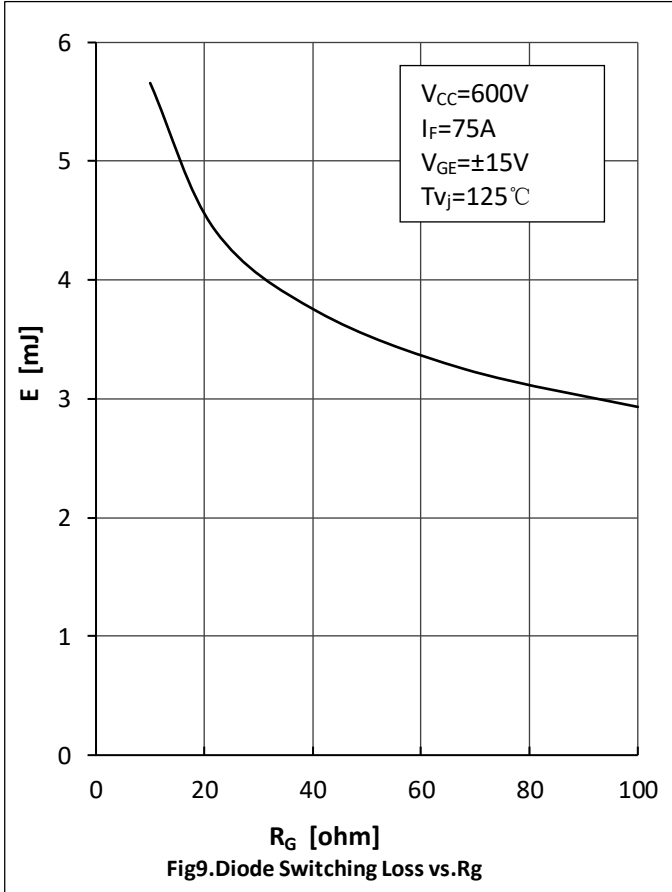

● **Circuit Diagram**

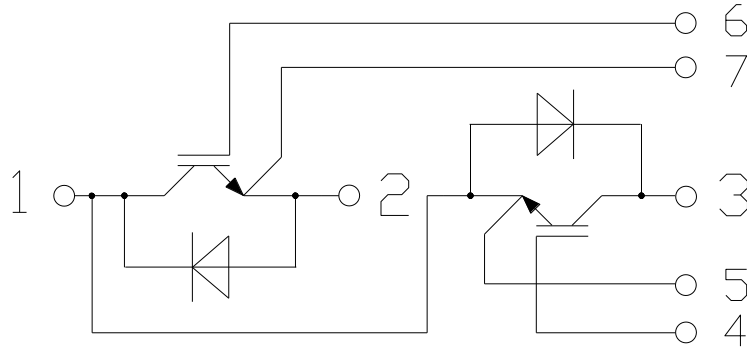

● **Package Outline Information**

Dimensions in Millimeters

