

SB4040S 40A SCRs

FEATURES

- High thermal cycling performance
- High voltage capacity
- Very high current surge capability

●APPLICATIONS

- Line rectifying 50/60 Hz
- Softstart AC motor control
- DC Motor control
- Power converter
- AC power control
- Lighting and temperature control

Parameters Summary

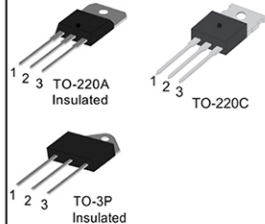
VD/VR:1200V/1600V IT(RMS):40A IGT :40mA

ABSOLUTE MAXIMUM RATINGS

Parameter	Symbol	Value	Unit
Storage junction temperature range	T _{stg}	-40 ~ 150	°C
Operating junction temperature range	T _j	-40~125	°C
Repetitive peak off-state voltage	V _{DRM}	1200/1600	V
Repetitive peak reverse voltage	V _{RRM}	1200/1600	V
Non repetitive surge peak Off-state voltage	V _{DSM}	V _{DRM} +100	V
Non repetitive peak reverse voltage	V _{RSM}	V _{RRM} +100	V
Non repetitive surge peak on-state current	I _{TSM}	420	A
RMS on-state current (180° conduction angle)	I _{T(RMS)}	40	A
Average on-state current (180° conduction angle)	I _{T(AV)}	25	A
I ² t value for fusing (tp=10ms)	I ² t	880	A ² S
Critical rate of rise of on-state current (I = 2×IGT, tr ≤ 100 ns)	di/dt	150	A/μS
Peak gate current	IGM	4	A
Peak gate power	PGM	5	W

Thermal Resistances

Symbol	Parameter	Value	Unit
Rth(j-c)	Junction to case (DC)	TO-220A	1.2
		TO-220C	0.8
		TO-3P	0.7

ELECTRICAL CHARACTERISTICS (T=25°C unless otherwise specified)				
Symbol	Test Condition		Value	Unit
I_{GT}	V = 12V R = 140Ω	MAX.	40	mA
V_{GT}		MAX.	1.5	V
V_{GD}	VD=VDRM Tj=125°C	MIN.	0.2	V
I_L	$I_G=1.2I_{GT}$	MAX.	200	mA
I_H	IT=50mA	MAX.	100	mA
dV/dt	$V_D=2/3V_{DRM}$ Gate Open Tj=125°C	MIN.	1000	V/μs

STATIC CHARACTERISTICS				
Symbol	Parameter		Value(MAX.)	Unit
V_{TM}	ITM = 60A tp=380μs	Tj = 25°C	1.5	V
I_{DRM}	$V_D=V_{DRM}$ $V_R=V_{RRM}$	Tj = 25°C	10	μA
I_{RRM}		Tj = 125°C	4	mA

Ordering Information Scheme

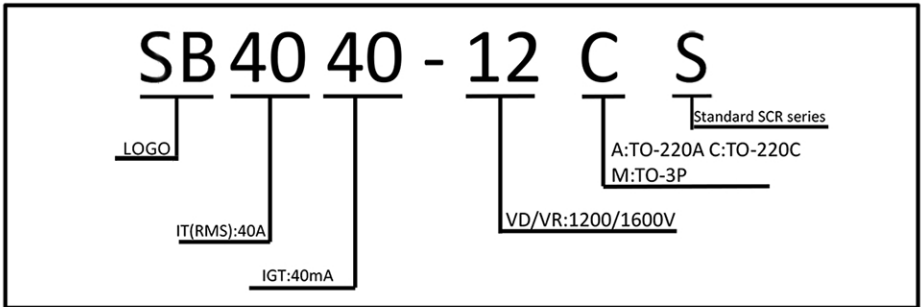

TO-220A Package Mechanical Data

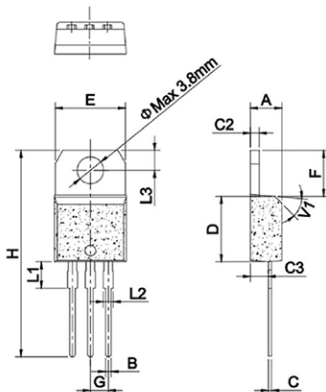

Ref.	Dimensions					
	Millimeters			Inches		
	Min.	Typ.	Max.	Min.	Typ.	Max.
A	4.40		4.60	0.173		0.181
B	0.70		0.90	0.028		0.035
C	0.45		0.60	0.018		0.024
C2	1.30		1.48	0.048		0.052
C3	2.20		2.60	0.087		0.102
D	8.90		9.90	0.350		0.390
E	9.90		10.3	0.390		0.406
F	6.30		6.90	0.248		0.272
G		2.54			0.1	
H	28.0		29.8	1.102		1.173
L1		3.39			0.133	
L2	1.14		1.70	0.045		0.067
L3	2.65		2.95	0.104		0.116
e		3.6			0.142	

TO-220C Package Mechanical Data

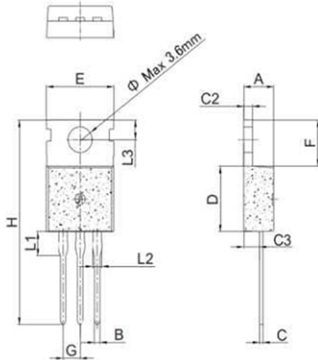

Ref.	Dimensions					
	Millimeters			Inches		
	Min.	Typ.	Max.	Min.	Typ.	Max.
A	4.40		4.60	0.173		0.181
B	0.70		0.90	0.028		0.035
C	0.45		0.60	0.018		0.024
C2	1.30		1.48	0.048		0.052
C3	2.20		2.60	0.087		0.102
D	8.90		9.90	0.350		0.390
E	9.90		10.3	0.390		0.406
F	6.30		6.90	0.248		0.272
G		2.54			0.1	
H	28.0		29.8	1.102		1.173
L1		3.39			0.133	
L2	1.14		1.70	0.045		0.067
L3	2.65		2.95	0.104		0.116
e		3.6			0.142	

TO-3P Package Mechanical Data

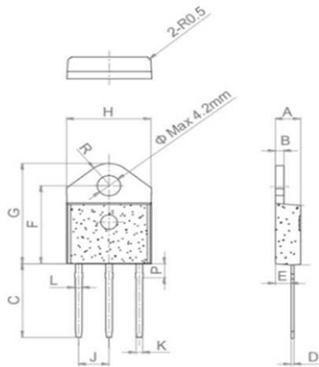

Ref.	Dimensions					
	Millimeters			Inches		
	Min.	Typ.	Max.	Min.	Typ.	Max.
A	4.40		4.60	0.173		0.181
B	1.40		1.60	0.055		0.062
C	15.48		15.88	0.609		0.625
C2	0.50		0.70	0.019		0.027
C3	2.70		2.90	0.106		0.114
D	15.92		16.32	0.626		0.642
E	20.27		20.67	0.798		0.813
F	15.15		15.35	0.590		0.604
G		5.45			0.214	0.216
H	1.10		1.30	0.043		0.051
L1	1.15		1.35	0.045		0.053
L2	2.68		3.08	0.105		0.121
L3		4.20			0.165	
e	4.40		4.60	0.173		0.181

FIG.1 Maximum power dissipation versus on-state current

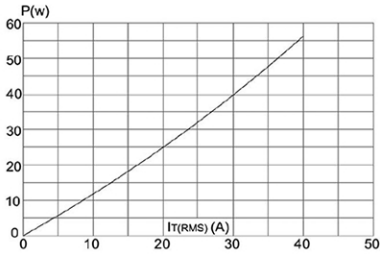

FIG.2: on-state current versus case temperature

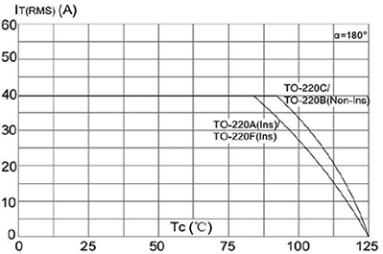

FIG.3: Surge peak on-state current versus number of cycles

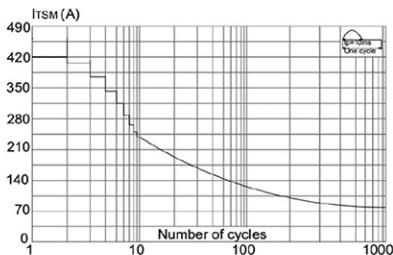

FIG.4: On-state characteristics (maximum values)

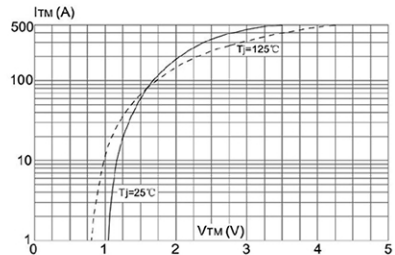

FIG.5: Non-repetitive surge peak on-state current for a sinusoidal pulse with width $t_p < 10\text{ms}$, and corresponding value of $I_2 t (di/dt < 50\text{A}/\mu\text{s})$

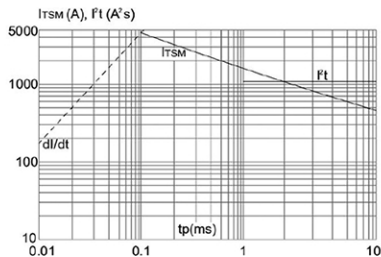

FIG.6: Relative variations of gate trigger current holding current and latching current versus junction temperature

